

GRIPPER GASKET™

*BOLTLESS RESTRAINT
FOR DUCTILE IRON PIPE,
VALVES AND FITTINGS*

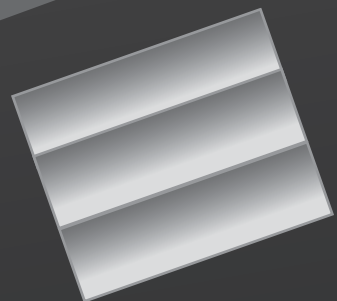

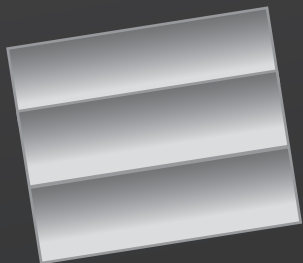

GRIPPER GASKET™

THE GRIPPER GASKET™

Used to instantly restrain Tyton Joint®¹ push-on ductile iron pipe, valves and fittings. The gasket design includes stainless steel teeth that automatically provide restraint upon installation. These gaskets eliminate nuts, bolts, clamps, thread rod, retainer glands, concrete thrust blocks and expensive labor associated with conventional restraining methods.

FEATURES



- Gripper™ restraining gaskets are certified to **NSF/ANSI 61** by NSF International.
- Boltless restraining gaskets (similar to Field Lok 350®)¹ shall be rated to 350 p.s.i. and tested in accordance with **ANSI/AWWA C111/A21.11**.
- Sizes available from 3" to 24".
- Styrene Butadiene Rubber (SBR) is our standard rubber compound. Nitrile (NBR) and EPDM gaskets available upon request.



Certified to NSF/ANSI 61

1. "Tyton® and Field Lok® are registered trademarks and properties of United States Pipe and Foundry Company, LLC. Gripper Gasket, LLC is not affiliated in any way with United States Pipe and Foundry Company, LLC."

Product Code	Part Name	Part Description
17030	GG3	3" Gripper Gasket
17040	GG4	4" Gripper Gasket
17060	GG6	6" Gripper Gasket
17080	GG8	8" Gripper Gasket
17100	GG10	10" Gripper Gasket
17120	GG12	12" Gripper Gasket
17140	GG14	14" Gripper Gasket
17160	GG16	16" Gripper Gasket
17180	GG18	18" Gripper Gasket
17200	GG20	20" Gripper Gasket
17240	GG24	24" Gripper Gasket

THE GRIPPER GASKET™ SUBMITTAL



Part

- A = Stainless Steel
- B = SBR
- C = Nominal Pipe Size
- D = USA
- E = Gripper Gasket™

Gripper Gasket™ Suggested Specification

Gripper Gasket™ 3" - 24":

Joint restraint for ductile iron water systems including pipe, valves and fittings shall be accomplished using integral boltless restraining gaskets. Pressure rating 350 psi. These gaskets shall be designed, manufactured and tested in accordance with AWWA C111/A21.11. Certified to NSF/ANSI 61. Boltless restraining gaskets shall be Gripper Gasket™ or equivalent.

MADE IN THE U.S.A. (ARRA Statement) The ARRA 2009 "Buy American" Provisions

American Recovery Reinvestment Act (ARRA) Section 1605 "Buy American" Requirements

Gripper Gasket LLC products comply with the American Recovery Reinvestment Act, Section 1605. Our products have always been manufactured in the United States of America. We take great pride in manufacturing only top quality "Made in the U.S.A." gaskets.

Gripper Gasket LLC cannot certify that accessories used with our products, such as pipe, valves, fittings, gauges, instrumentation or like components are made in the U.S.A. We pledge to encourage the use of products made in the U.S.A.

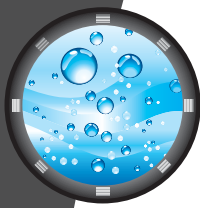

GRIPPER GASKET™

ASSEMBLY

1. Sealing Bulb
2. Gasket Heel
3. Stainless Steel Teeth
4. Bell Ridge
5. Retainer Seat
6. Spigot/Plain End

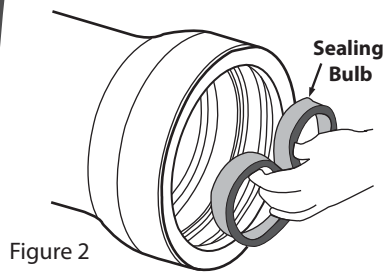
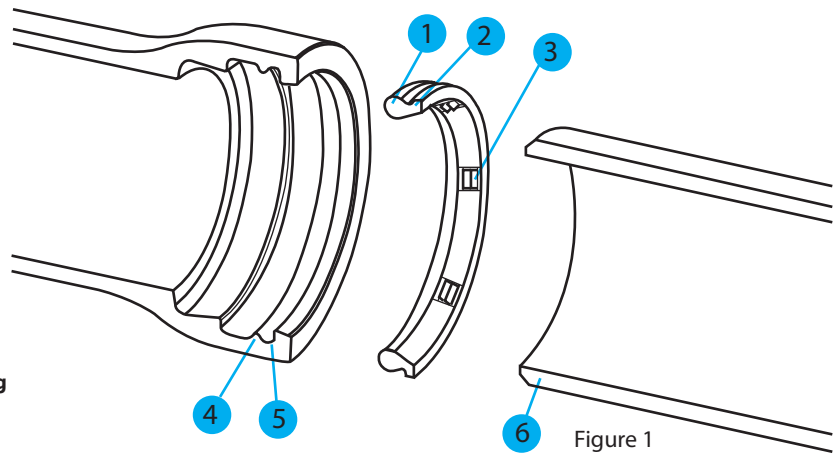

Figure 2

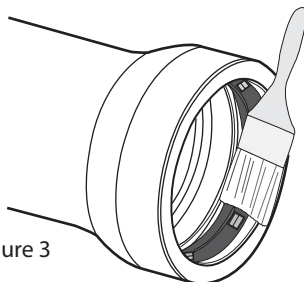

Figure 3

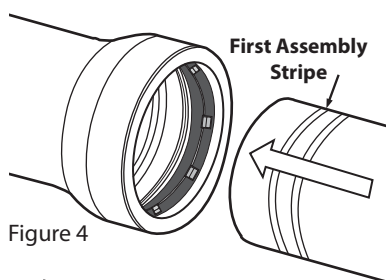

Figure 4

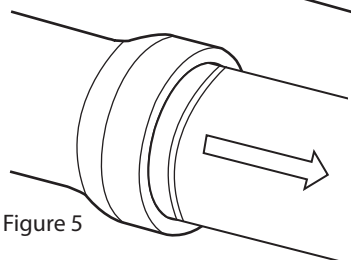

Figure 5

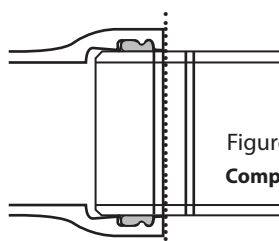

Figure 6

Completely Assembled Joint

1. Inspect and clean pipe and gasket. Ensure they are in good order, free from debris. Grind or file sharp edges that could damage the gasket when it is inserted. Carefully remove foreign matter such as tar or paint in the gasket groove.

In cold weather (40° F/4.4° C) it is more difficult to clean surfaces but the removal of ice, dirt and debris is still required. Warming cold, stiff gaskets will ease assembly.

2. Insert the gasket. (Fig. 2) Loop the gasket and insert the rounded bulb-end first, placing the gasket heel in the retainer seat. Make sure not to install the gasket behind or underneath the retainer seat. Release the loop to allow the gasket to expand into the recess. Check with your fingers to be certain it is properly seated. Large gaskets may require multiple loops evenly spaced around the gasket.

3. Lubricate the spigot end and gasket. (Fig. 3) Apply a thin film of joint lubricant to the outside of the spigot end and to the surface of the gasket that will contact the spigot end. Do **not** lubricate the bell socket of the pipe or the surface of the gasket that contacts the bell socket.

4. Join the spigot end to the bell. (Fig. 4) Ensure the plain end of the pipe is beveled (See page 5, Field Cut Pipe) - square or sharp edges may damage or roll the gasket. Insert the spigot end into the bell and keep both sections of the pipe aligned without deflection. Insert pipe until the entire first assembly stripe has disappeared into the bell. After insertion to the first assembly stripe, the pipe can be deflected (See page 5, Table 2). Use a feeler gauge to ensure that the gasket has not been dislodged from proper placement during installation.

5. Reverse the assembly force. (Fig. 5) Apply a setting force in the opposite direction of assembly to engage teeth. Up to 0.25" of extension can be expected to set teeth. If the joint does not assemble properly, disassemble it and check for debris, proper positioning of the gasket, and adequate lubrication.

NOTE: The Gripper Gasket™ is not to be reused.

FIELD CUT PIPE

Bevel the edge of the field cut pipe 1/4" at a 30° angle. Round the leading edge and remove sharp edges which could damage the gasket. When cut pipe with no assembly stripes is to be assembled, the spigot insertion depth should be marked on the spigot to ensure that the joint is fully assembled (See Table 2).

When deflection is required at the joint, the spigot should not be completely homed.

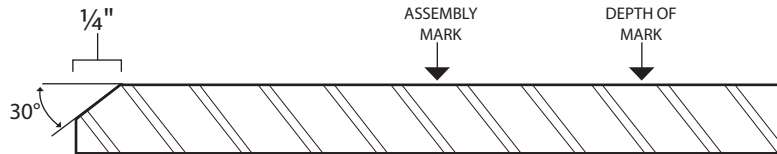

PIPE DIAMETERS

Table 1. Suitable Pipe Diameters for Field Cuts and Restraint Joint Field Fabrication

NOMINAL PIPE SIZE Inches	PIPE DIAMETER Inches		PIPE CIRCUMFERENCE Inches	
	MINIMUM	MAXIMUM	MINIMUM	MAXIMUM
3	3.92	4.00	12-5/16	12-9/16
4	4.74	4.86	14-7/8	15-9/32
6	6.84	6.96	21-15/32	21-7/8
8	8.99	9.11	28-1/4	28-5/8
10	11.04	11.16	34-11/16	35-1/16
12	13.14	13.26	41-9/32	41-21/32
14	15.22	15.35	47-13/16	48-7/32
16	17.32	17.45	54-13/32	54-13/16
18	19.42	19.55	61	61-13/32
20	21.52	21.65	67-19/32	68-1/32
24	25.72	25.85	80-25/32	81-7/32

ASSEMBLY MARK AND DEFLECTION

Table 2. Assembly Mark and Deflection

PIPE SIZE Inches	LOCATION OF ASSEMBLY MARK Inches	MAXIMUM JOINT DEFLECTION Degrees	MAXIMUM DEFLECTION PER JOINT Inches	
			18 ft. Laying Length	20 ft. Laying Length
3	2-5/8	5	19	21
4	2-3/4	5	19	21
6	2-15/16	5	19	21
8	3-1/4	5	19	21
10	3-5/16	5	19	21
12	3-5/16	5	19	21
14	4-9/16	4	15	16.5
16	4-9/16	4	15	16.5
18	4-9/16	4	15	16.5
20	5-1/16	2.5	9.5	10.5
24	5-1/2	2.5	9.5	10.5



GRIPPER GASKET™

DISASSEMBLY TOOL



The Gripper Gasket™ Disassembly Tool allows you to position the handle where you need it for those hard to reach places. This tool comes complete with tempered steel shims.

Additional tempered steel shims are available.

DISASSEMBLY TOOL KITS

SK-12	Removes up to 12" gasket. Includes 15 shims.
SK-16	Removes up to 16" gasket. Includes 20 shims.
SK-24	Removes up to 24" gasket. Includes 30 shims.
RS-1	Pack of 10 shims.

DISASSEMBLY INSTRUCTIONS

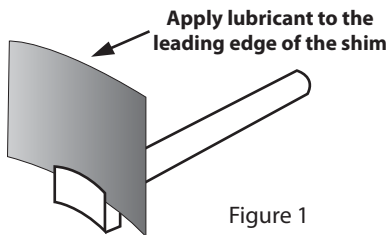

Figure 1

Note: It will ease installation of shims if pipe can be pushed together a little to disengage the teeth of gasket from spigot end.

Wearing gloves to protect hands, insert an extractor shim into the slot of the tool. (Fig. 1) Apply lubricant over the leading edge of the shim.

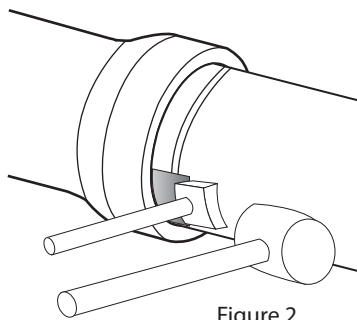

Figure 2

Being sure to wear safety glasses, commence at the bottom of the joint. (Fig. 2) Drive shim under the gasket by striking the tool with a heavy hammer. Continue driving shims under the gasket around the entire circumference of the joint. Keep the gap between the shims to a minimum.

Insert the final shim so that it is overlapped by the shims on either side. (Fig. 3) After all shims have been properly installed, the joint can be separated by pulling, using a cable and a backhoe or other equipment to force joint separation.

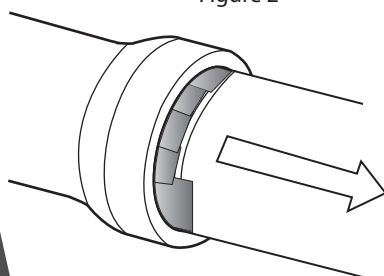
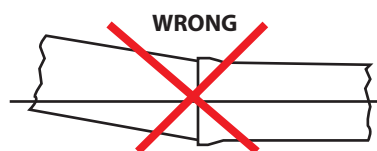
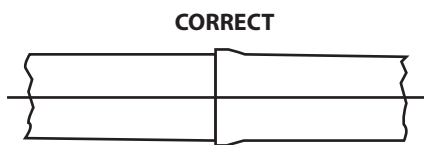

Figure 3

NOTE: Do not reuse the Gripper Gasket™.

SPECIAL NOTES REGARDING THE USE OF GRIPPER GASKET™

1. Do not use Gripper Gaskets™ to provide electrical joint conductivity for thawing purposes. Such use may damage the gaskets.
 2. Use Gripper Gaskets™ only in push-on joints which have the trademark Tyton®, Trim Tyton® or Tyton Joint®¹. Use in other joints may result in joint separation.
 3. Gripper Gaskets™ should not be used in above ground installations.
 4. Do not use Gripper Gaskets™ with corroded pipe.
 5. Gripper Gasket LLC has not conducted tests with gray iron or plastic piping products and, therefore, cannot recommend or warrant the use of Gripper Gasket™ with gray iron (pipe, fittings or valves) or plastic (pipe or fittings).
 6. Always make sure the gasket is properly placed in the socket with the sealing bulb or thickest portion of the gasket being deepest in the socket.
 7. Use in casings: Pipelines restrained with Gripper Gaskets™ may be installed in straight casings by pulling, not pushing, the pipe through the casing. Assembly of the joints must be controlled, such as with come-a-longs or cable hoist, to prevent fully "homings" spigot to base of the socket to allow for joint deflection.
 8. Do not reuse Gripper Gaskets™.
 9. Do not use Gripper Gaskets™ with Tyton Plugs¹ since it is not possible to remove the plug after the joint is assembled.
 10. If the maximum joint deflection is necessary, do not push the pipe to the bottom of the socket.
 11. For cold weather assemblies, keep the temperature of the Gripper Gasket™ above 40° F.
 12. Approximately twice as much assembly force may be required to assemble a Gripper Gasket™ joint as is required for a conventional Tyton® Gasket¹ push-on joint.
 13. The Gripper Gasket™ should not be used on pipe and fittings which have thick coatings or tape wrap on the outer diameter of the pipe. In general, if the peen pattern is not visible on the pipe surface, the asphalt coating may be too thick for proper penetration of the teeth of the Gripper Gasket™. The thick coating should be removed from the end of the pipe or fitting before assembly. The coating must be no more than 2 mils thick for asphalt coating and 6 mils nominal thickness for 2 part epoxy coating on the plain end of the pipe.
 14. Concrete Thrust blocking or other means of thrust restraint is not required to be used with Gripper Gaskets™ when Gripper Gaskets™ are used in a designed thrust restraint system. The Thrust Restraint Design for Ductile-Iron Pipe published by the Ductile-Iron Pipe Research Association (DIPRA) is one method used to calculate the required length of restraint at a change in direction. This program is available online at www.dipra.org.
- Pressure Rating: The working pressure rating of the Gripper Gasket™ Restrained Joint System does not exceed that of the working pressure rating of the pipe in which it is installed.*
15. If Gripper Gaskets™ are used in vertical installations, provisions must be made to keep the joint extended and not allow the teeth to become disengaged from the pipe. Failure to keep vertical joints extended can result in joint separation.
 16. For cut pipe, select pipe with diameters or circumferences at the cut location which conform to Table 1 (Page 5).
 17. For cut pipe, ensure that a tapered bevel similar to the one furnished with the pipe is ground on to the end of the pipe.
 18. Measure the socket depth and make a mark on the pipe spigot that distance from the end of the pipe. This mark will indicate when the joint is fully "home".
 19. Keep the joint in straight alignment during assembly, especially when handling fittings. Do not fully "home" the joint if maximum joint deflection is required. Set the joint deflection after the assembly is made.
 20. Check for correct positioning of the Gripper Gasket™ by inserting a feeler gauge in the space between the bell and the pipe OD in several locations around the socket to assure that the gasket is in proper position in the socket.



1. "Tyton® and Field Lok® are registered trademarks and properties of United States Pipe and Foundry Company, LLC. Gripper Gasket, LLC is not affiliated in any way with United States Pipe and Foundry Company, LLC."

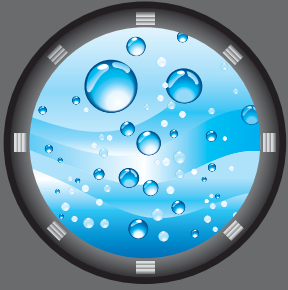

GRIPPER GASKET™



GRIPPER GASKET LLC

P.O. Box 1475

Corona, CA 92878

(951) 479-4999

(951) 479-4997 Fax

www.gripper-gasket.com

